

Hydraulic Ram Control Unit HSE NG 25

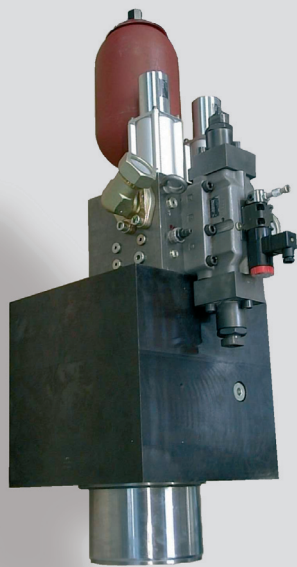

Pumps and Hydraulic **Solutions**
from Voith Turbo H+L hydraulic.
Systems **Especially for You**

Design and Function

Common features of VTHL ram control units:

- modular design
- robust valve elements
- high dynamics
- simple control structure

The integration of all necessary valve components into a manifold mounted directly on the block cylinder results in a compact design and best power density. Together with additional mechanical feedback, the hydraulically piloted main valve

forms the basis for the stroke control.

Tdc (top dead center) control is always with mechanical closed loop feedback. Bdc (bottom dead center) control may be with electrical feedback or with mechanical feedback control, depending on the application.

The hydromechanical design of the stroke control unit offers an accurate and drift-free tdc. Due to the fast steering process, the bdc has a good repeatability as well.

Features

- highly dynamic punching and shearing drive for shortest cycle time
- smooth stroke operation via hydraulically damped cylinder ram
- stable tdc position without drift
- exact bdc reversing for process safe stroke operation
- manually adjustable stroke positions; optionally electrical
- simple functions with robust valve technique
- monitored processes with low control complexity

Options

- ram control units NG 6 and NG 10 for lower force range
- ram control unit HSP for programmable stroke positions
- complete punching systems

Applications

- punching/nibbling
- shearing/cutting
- stamping

Examples of Applications

Application	Specific Performance
Linear Punching Installation	Punching force: 1600 kN Total cycle time at 6 mm stroke: 125 ms
Section Shearing Machine	Shearing force: 800 kN Total cycle time at 100 mm stroke: 860 ms

Technical Data

General		
Ram force	kN	up to 2000 (standard design)
Ram return force		approx. 20% ram force
Operating force tdc	N	450 at 80 bar control pressure
Operating force bdc	N	150 (at mechanical bdc reversal)
Ambient temperature	°C	-5 to +50
Mounting position		mountable in any position
Hydraulic		
Operating pressure	bar	max. 250
Control pressure	bar	80
Hydraulic oil temperature	°C	-10 to +70
Viscosity range	mm ² /s	10 to 300
Electric		
Valve control		VTHL stroke control HS2 (data sheet: 9.1.1)
Valve voltage (±10%)	V	24 DC
Switching time „Start“	ms	8 ms (HS2)
Valve switching time from „bdc“	ms	7 ms (HS2)
Power consumption P20	W	20
System of protection DIN 40050		IP65 with valve plug connected

Further specific performance data according to computation minutes.

Functional Diagramm HSE NG 25 with electric bdc reversing

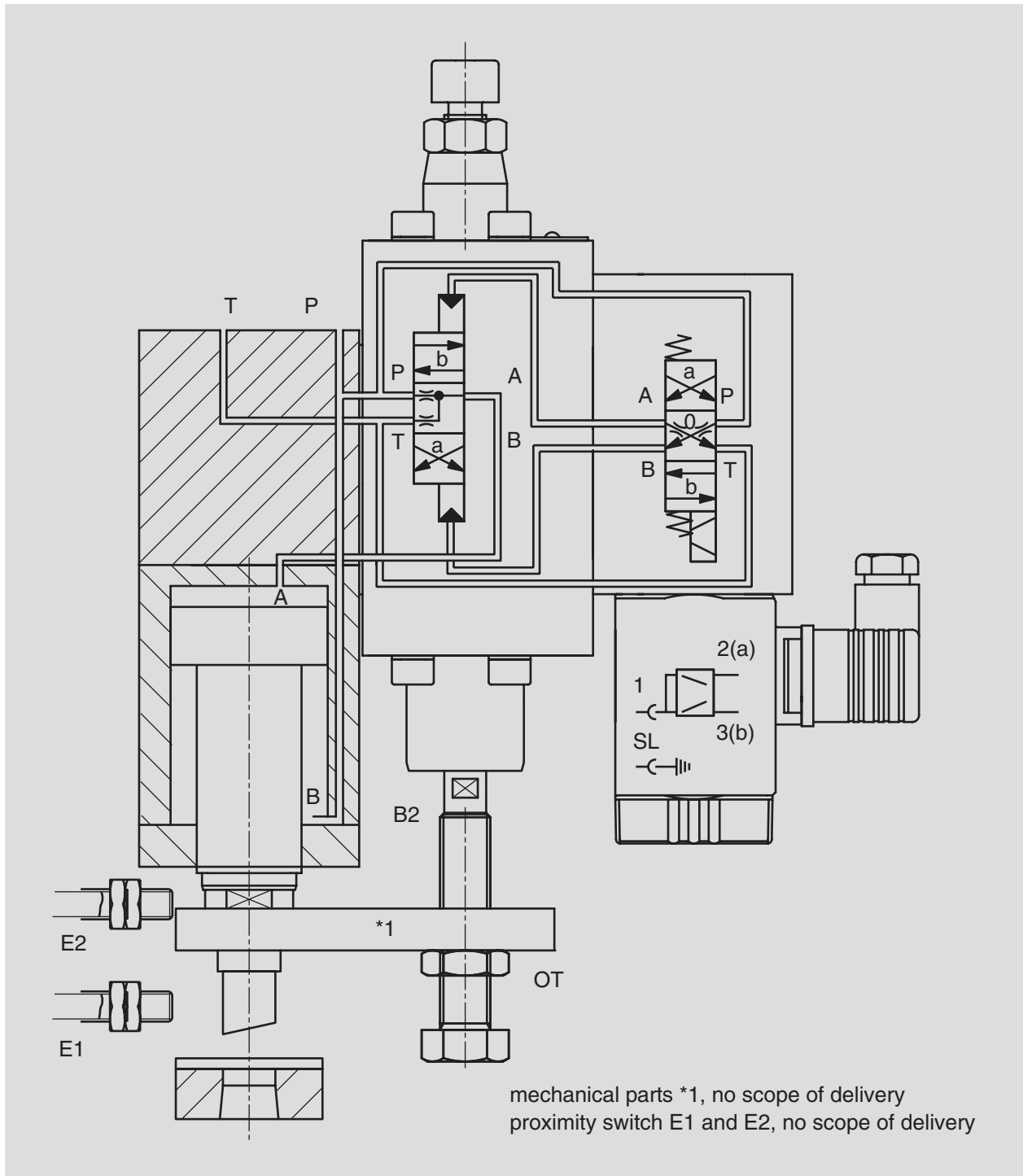

Functional Diagramm HSE NG 25 with mechanic bdc reversing

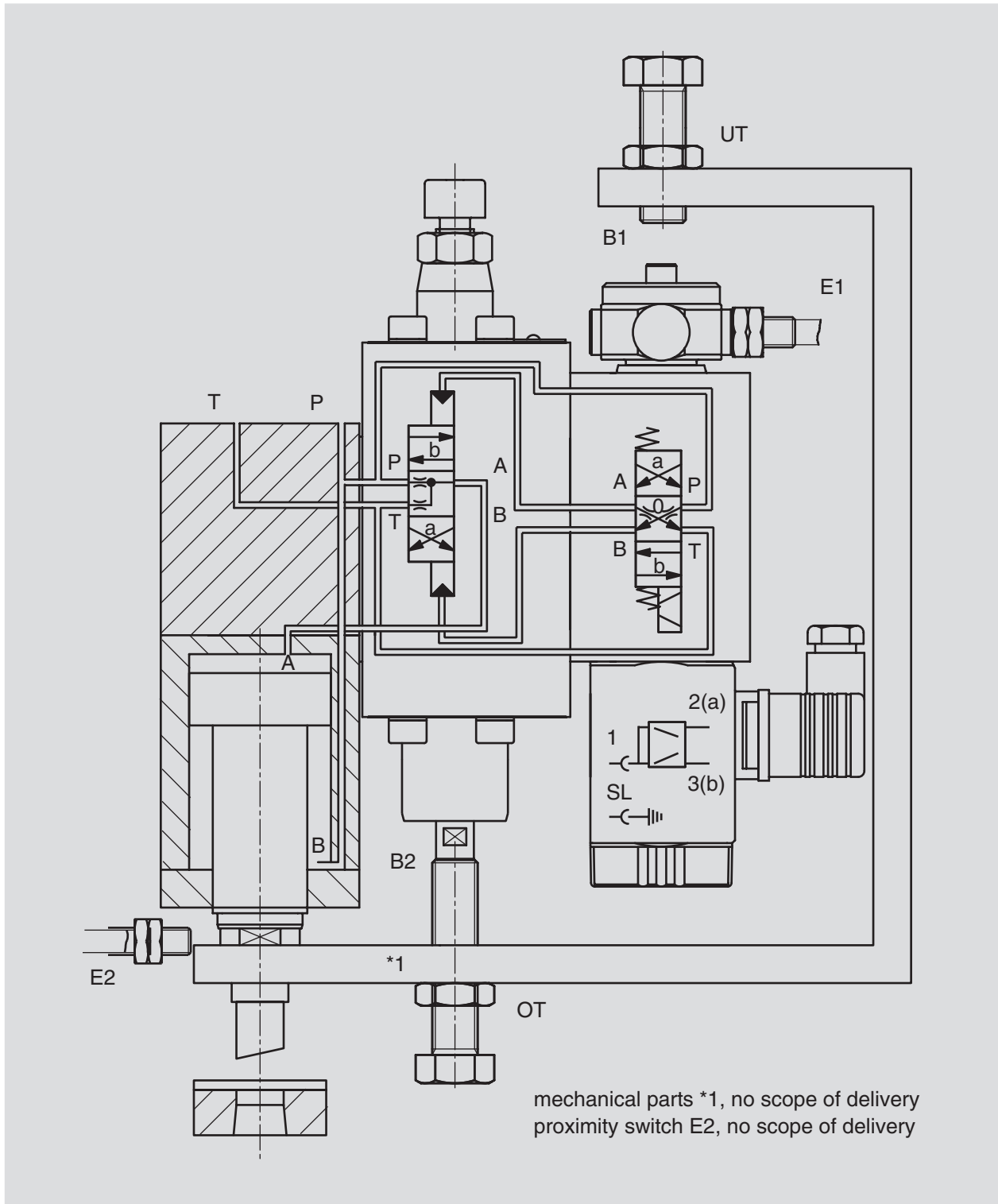

Dimensioned Drawing Basic Design

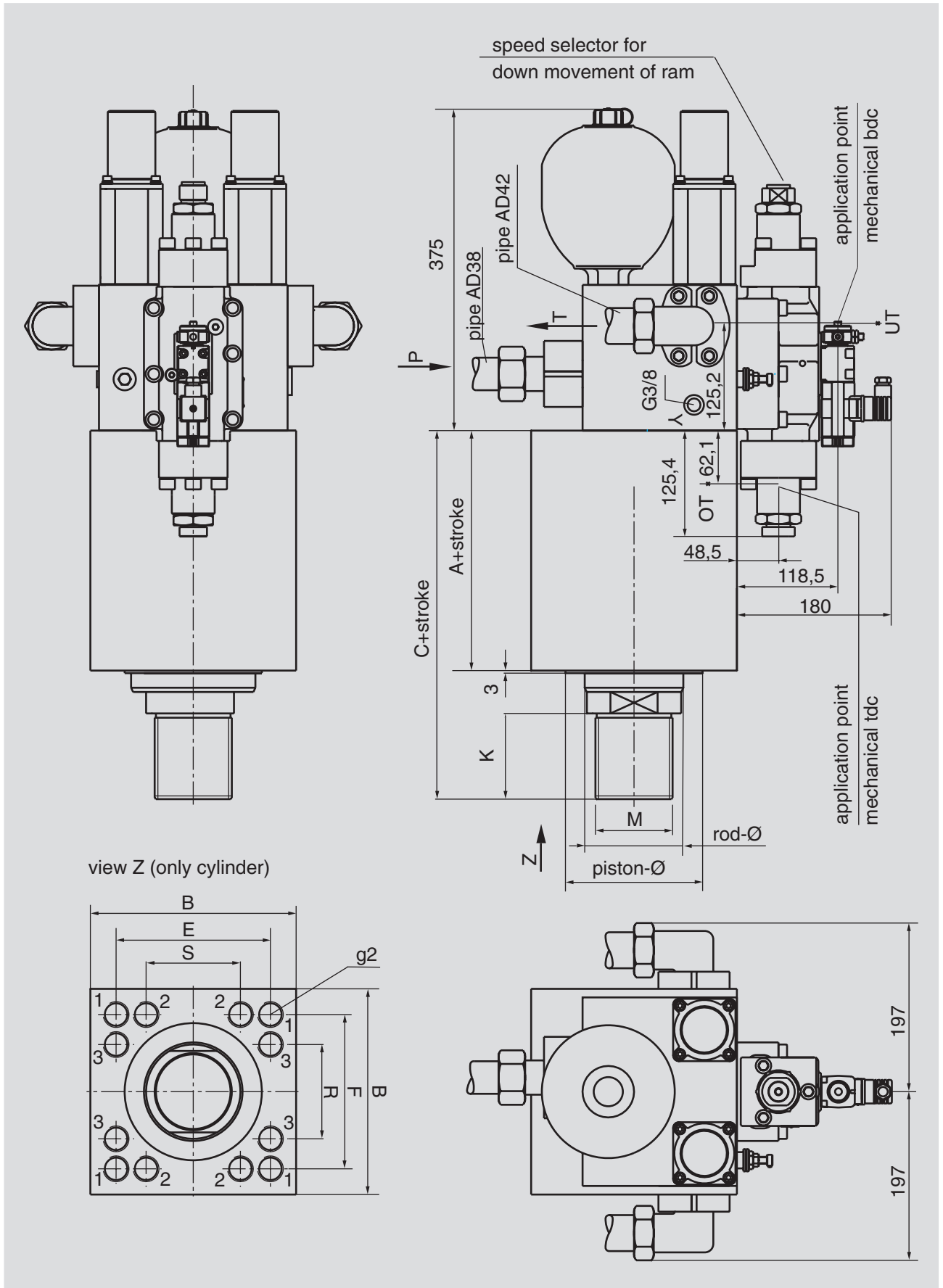

Dimension Table Standard Cylinders

Piston diameter	Rod diameter	Wall thickness	A	C	K	M	g2 (position)	B	E	F	R	S
120	110		215	325	80	M64 x 3	4 x M24 (1)	*	130	130	-	-
140	130		220	350	90	M80 x 3	4 x M30 (1)	*	160	160	-	-
160	145	40	240	390	100	M90 x 3	4 x M30 (1)	240	180	180	-	-
180	160	50	260	410	100	M100 x 3	8 x M27 (2/3)	280	210	210	120	120
200	180	60	280	430	100	M120 x 3	8 x M30 (2/3)	320	260	260	140	140
220	200	60	300	450	100	M140 x 3	8 x M30 (2/3)	340	270	270	150	150
240	220	60	320	490	120	M150 x 3	8 x M36 (2/3)	360	280	280	160	160
260	240	70	380	540	140	M160 x 3	8 x M36 (2/3)	400	310	310	180	180
280	255	80	420	610	140	M170 x 3	8 x M42 (2/3)	440	340	340	200	200
300	270	75	460	680	150	M180 x 3	12 x M36 (1/2/3)	450	350	350	200	200
320	290	90	460	710	180	M220 x 3	12 x M36 (1/2/3)	500	400	400	225	225
340	310	95	500	760	180	M240 x 3	12 x M42 (1/2/3)	530	430	430	255	255
360	330	120	530	800	200	M250 x 3	12 x M42 (1/2/3)	600	500	500	300	300

further cylinder dimensions on request

all data in mm

* cylinder rectangular, dimension B: 180 and 210

Type Code

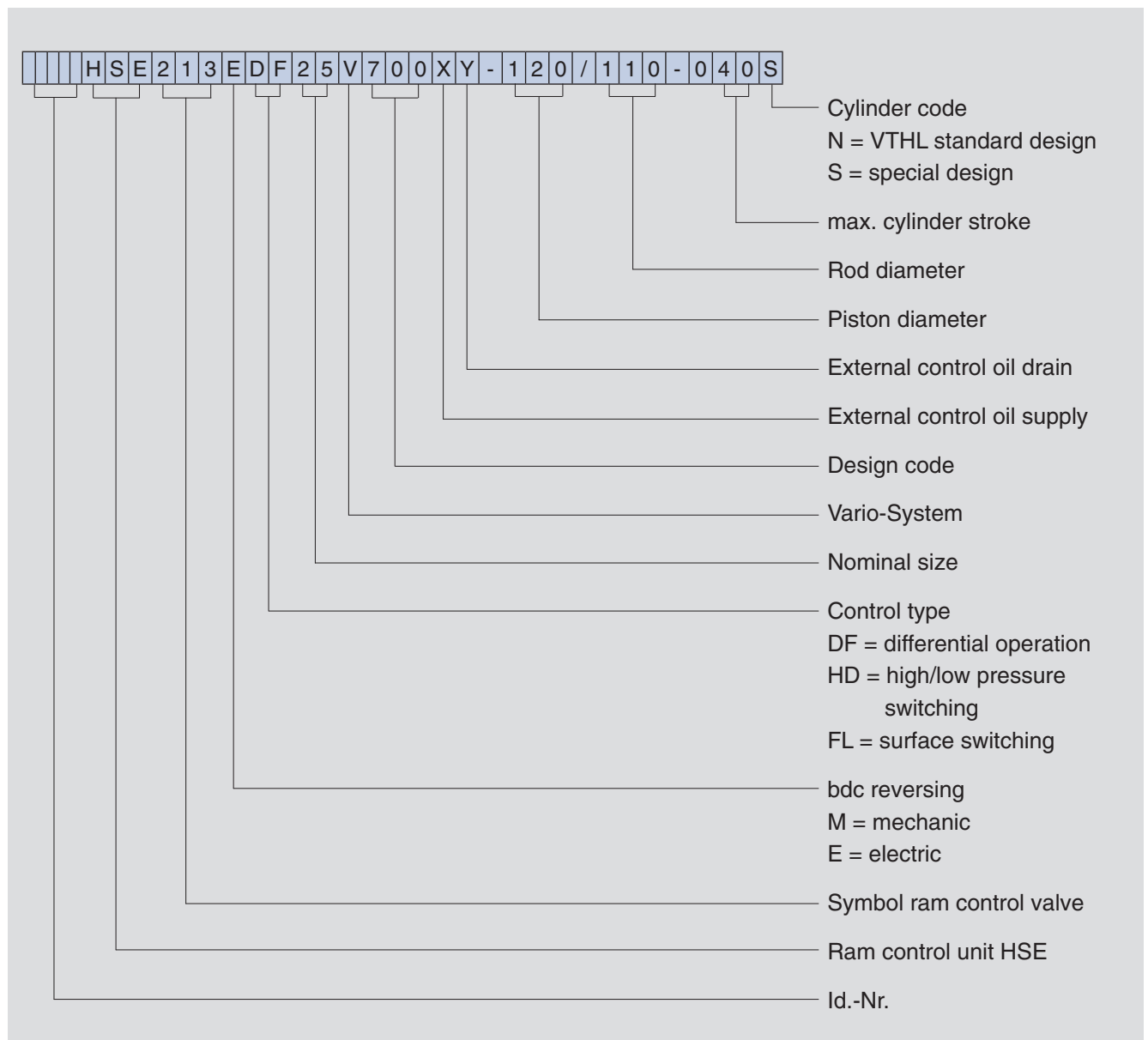

Electronic Control

The ram control units HSE are delivered with an electronic control, the link between hydraulics and machine control. This control is adapted to the application.

Please refer to the technical data from the data sheet of the electronic control.

Electronic Control	Data Sheet
HS2	9.1.1
HS3	9.1.2

Voith Turbo H + L Hydraulic GmbH & Co. KG
Schuckertstraße 15
71277 Rutesheim, Germany
Tel. +49 (0)7152/992-3
Fax +49 (0)7152/992-400
sales-rut@voith.com
www.voithturbo.com

VOITH
Engineered reliability.